

DOLAV[®]
PLASTIC PRODUCTS

BOX PALLET TYPE

1000-ACE

Premium Line Designed for Hygiene

- Three integrated injected runners
- Rounded interior corners
- Easily steam cleaned
- Sturdy and durable, for long life span

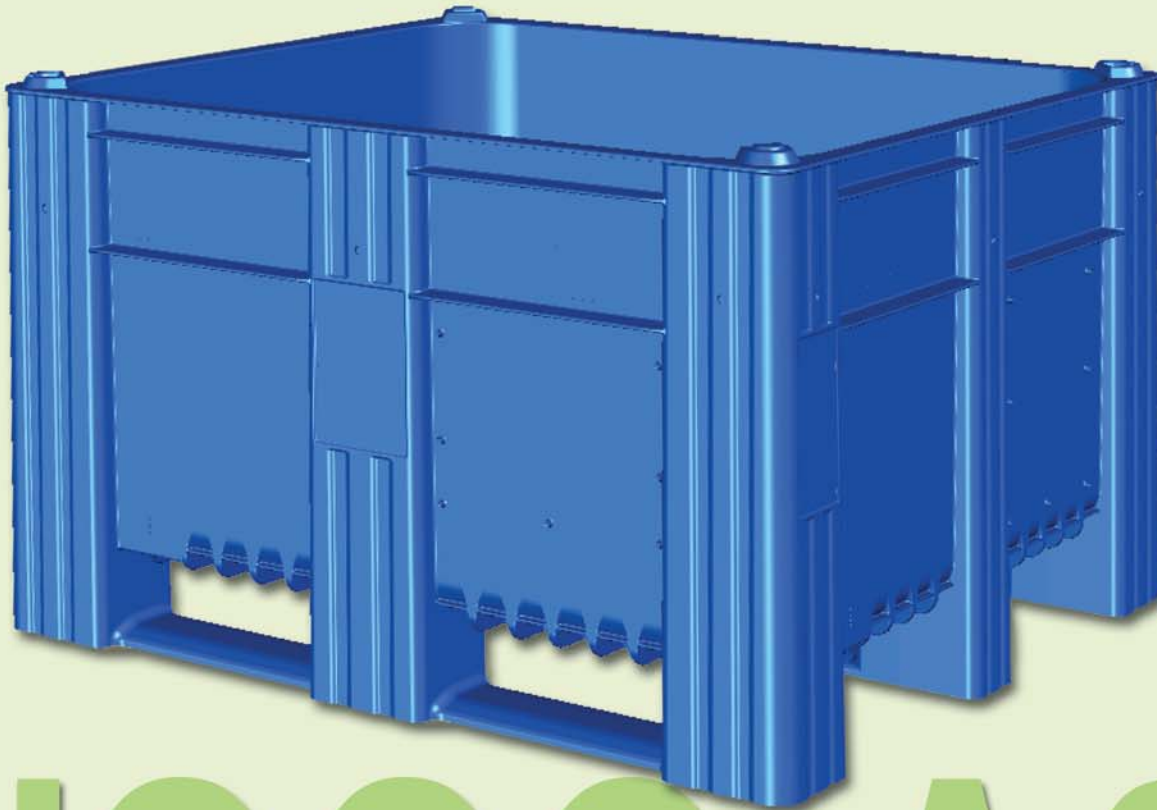

1000-ACE



BOX PALLET TYPE 1000-ACE

Features

- Specially designed for the food industry.
- Free from "dirt traps".
- Light weight.
- Three integrated runners provide excellent tipping performance.
- Three lower deck options – three runners, two runners or nine feet.
- Additional optional ribs, for extra heavy duty uses.
- Suitable for use on conveyers and rollers.
- Ticket holder can be attached without damaging hygienic integrity.
- Built-in drainage option.
- Special area for application of stickers.
- Innovative column design enables stacking up to 5000 Kg.



Your Logo on DOLAV Products



Embossed



Name Plate



Silk Screen/Hot Stamping



Sequential Numbering

Ticket Holder (Optional)

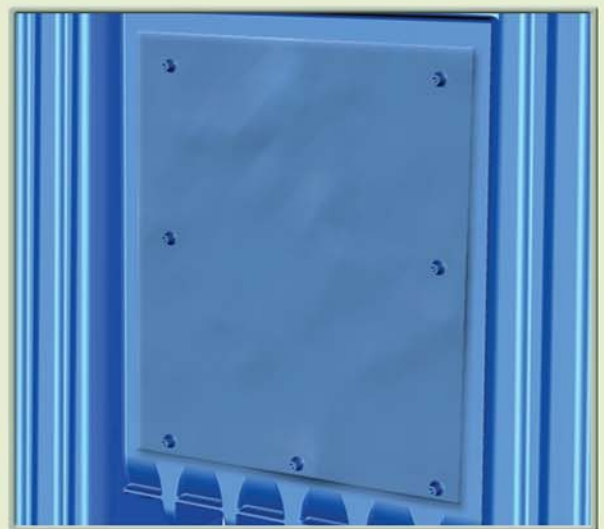

Colours



Green



Grey



Yellow



Blue

Large Interior Radius

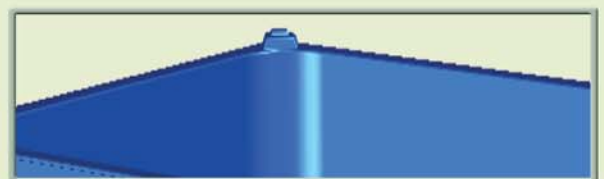

Provides hygiene and product protection.

Other colour options are available for quantities above 312.

Stacking

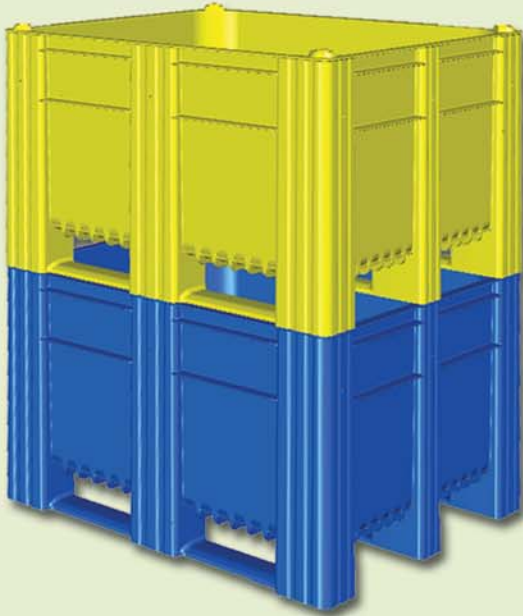

Secure Nesting

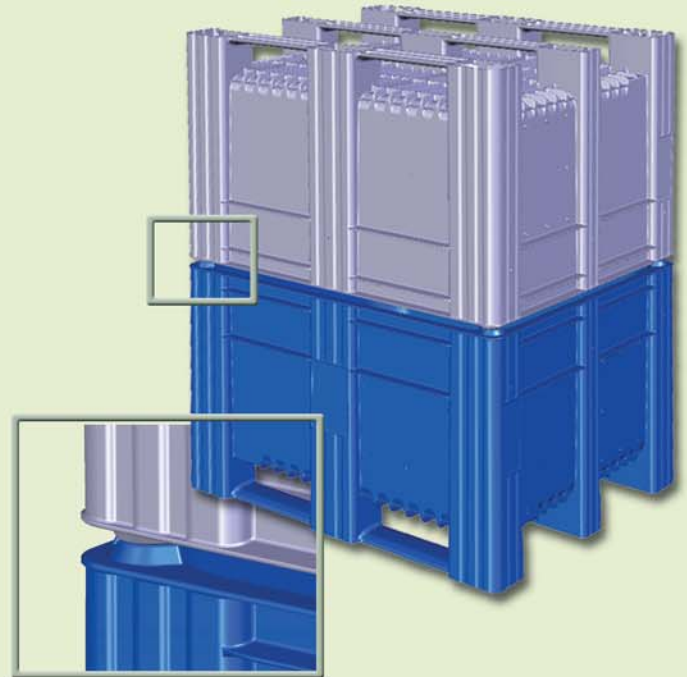

3 Integrated Injected Runners

Uniquely designed plastic runners are "built-in" during the production process.



Anti-slip Corners

A unique stacking system with inter-locking plugs, allow safe stacking of up to 8 boxes. Compatible with all Dolav designs.

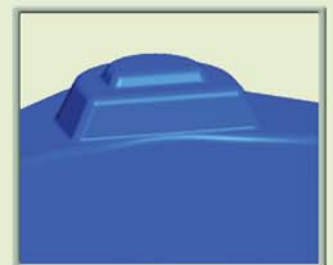
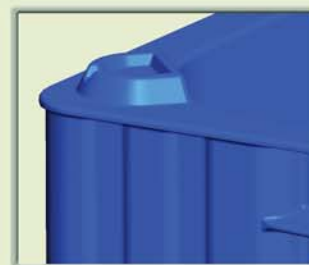
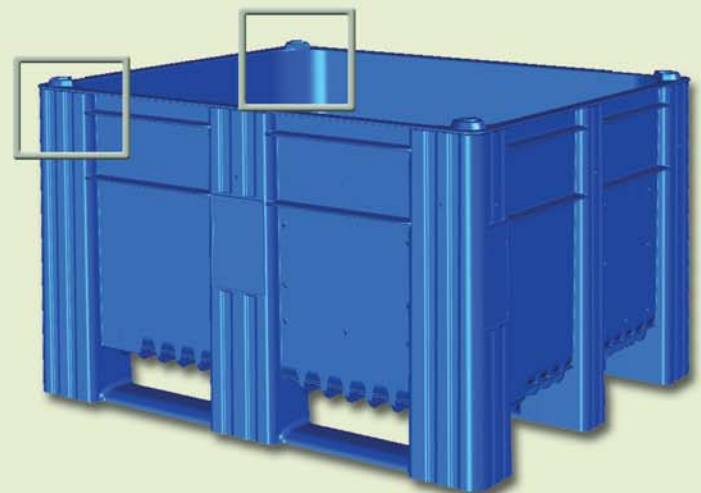

BOX PALLET TYPE 1000-ACE

Options

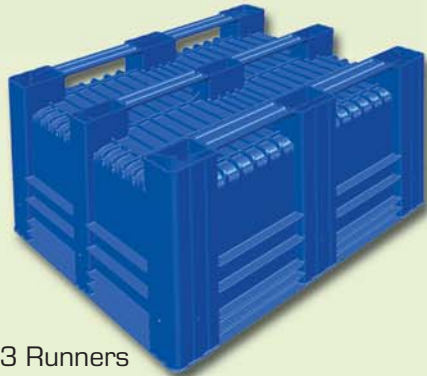

3 Runners



2 Runners

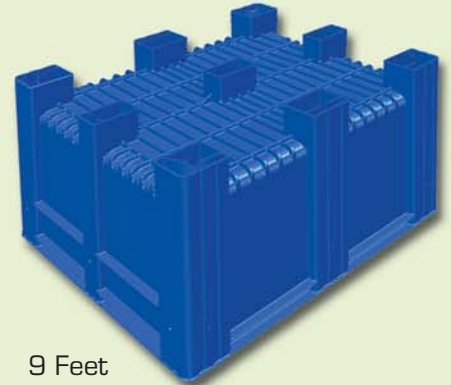

9 Feet

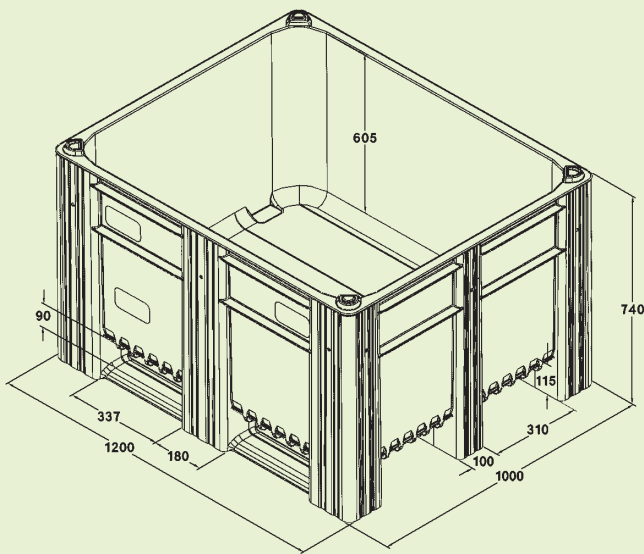

Logo

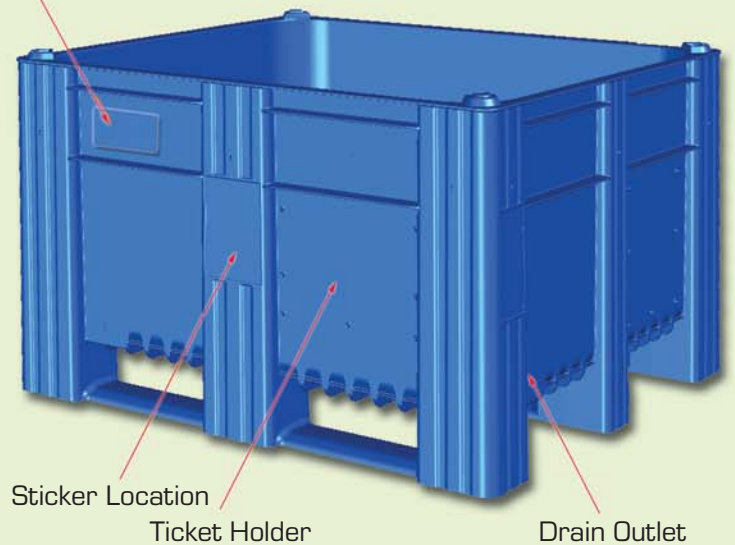

Technical Data

	Solid			Perforated		
	3-runners	2-runners	9-feet	3-runners	2-runners	9-feet
Cat. No.	1500300000	1500100000	1500200000	1510300000	1510100000	1510200000
External Dimensions (mm)	1200 x 1000 x 740					
Internal Dimensions (mm)	1128 x 928 x 605					
Volume (liter)	620					
Material	HDPE					
Temperature Range	-40°C - +60°C					
Tare Weight (kg)	36.5	35.5	34	35.5	34.5	33
Max. Load (kg)	900	700	700	900	700	700
Max. Stacking Load (kg)	5,000	4,000	4,000	5,000	4,000	4,000
Quantity in Container (Units)	20ft	40ft	40ft HC	20ft	40ft	40ft HC
	40	86	104	40	86	104

Notes:

- Data refers to temperature of 23°C.
- Tare weight tolerance is ±0.5kg.
- Maximum stacking load refers to vertical loading when the load in each box pallet does not exceed 500kg.
- Also available with combination: solid walls and perforated base or perforated walls and solid base.



Kibbutz Dvir, M.P. HaNegev, 85330, Israel
 Tel: 972-8-911-1700, Fax: 972-8-991-8710
 E-mail: dolav@dolav.com www.dolav.com